

Operating Instructions

Brinkmann Cutter pumps of the series SFC850 ... 1150

Contents

1 General.....	1	7 Servicing and Maintenance	3
2 Safety	1	8 Trouble shooter's guide.....	3
3 Transport and storage	1	9 Spare parts.....	4
4 Description of product and accessories	1	10 Replacing insert shaft.....	5
5 Installation	2	11 WARRANTY.....	6
6 Start up / Shut down.....	2		

1 General

These operating instructions apply to the pumps of the series SFC850...1150 with different depths of immersion and specifications. The cutter pumps are suited for cutting aluminum chips or similar materials and for pumping these materials along with the coolant fluid. An agitator located at the pump suction helps to break up and separate any large bundles of chips or birds nests which reach the pump suction.

These operating instructions contain basic information and instructions which must be observed when the pump is being installed, operated or repaired. Therefore it is important that these operating instructions are read by the fitter, the operator and relevant technical personnel before installation and start-up, and they are available at all times at the place where the unit/system is being operated.

Specifications

Type	Max. del. pressure spec. weight 1		Max. del. volume		Depth of im- mersion		Weight		Power		
	PSI	bar	GPM	l/min	Inches	mm	kg	HP	kW		
SFC850S	290	24	1.6	300	1200	11.50	292	139	63	5.4	4.0
	390					15.43	392	143	65		
	520					20.55	522	148	67		
	640					25.28	642	154	70		
SFC1150 S	290	32	2.0	400	1580	11.50	292	163	74	5.5	5.5
	390					15.43	392	168	76		
	520					20.55	522	172	78		
	640					25.28	642	179	81		

Mediums:	water, water-soluble coolants, cooling and cutting oils
Chip material: Aluminium	Max. chip to coolant ratio by weight: 1.5%
Chip geometry: Chip bundles	
Kinetic viscosity of the medium	...415 SSU (.... 90 mm ² /s)
Temperature of medium	30...175 °F (0 80 °C)

2 Safety

See appendix A.

3 Transport and storage

Protect the pump against damage when transporting.

Store pump in dry and protected areas and protect it against penetration of foreign bodies.

ATTENTION

Pump may not be placed on its pump end!

Protective packaging should remain on the pump end until its installation.

4 Description of product and accessories

Pumps of the series SFC850...1150 are one-stage rotary pumps. The impellers are fixed on the driving shaft extension. The hardened cutting unit (>60HRC) is cutting the chips and the semi-open impeller with its large clearances allows to pump the particles along with the coolant fluid from the machine back to the filter. The SFC pumps are capable of handling chip to coolant ratios of up to 1.5% by weight. Pump and motor form a compact and space-saving unit.

The motor is surface cooled and complies with the DIN IEC 34 resp. EN 60034 (IP 55).

Tension voltage and frequency must correspond with the shown specification on the nameplate. The terminal links of the motor are delivered in star connection from the plant. A circuit breaker or overload trip must be provided and the tripping current adjusted to correspond with the motor rated current.

Special electrical or mechanical versions are described in appendix B!



Check the terminal links according to the following wiring diagram.

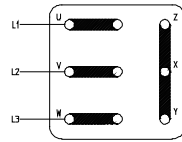

YY
Low Voltage

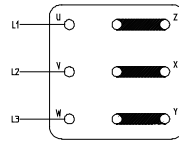

Y
High Voltage

Voltage changing 1:2 YY / Y
e.g. 230 / 460 V, 60 Hz



Work on the electrical equipment must only be carried out by a qualified electrician.

The motor must be isolated before any work is carried out.

5 Installation

The pumps are mounted on the top of the coolant tank with the pump body being immersed in the coolant. Pumps must be mounted securely. The pipework must be installed so that no distortion of the pump can occur. According to the drawing shown on the right, the maximum liquid level must stay about 1.2 Inches (30 mm) below the mounting flange. The pump begins to prime once the liquid level reaches the agitator. The pump suction is at the bottom of the immersed pump body. The pump draws the fluid level down to the level of the agitator. The bottom of the agitator must be located 4 inches (100 mm) above the tank bottom in order to prevent unwanted objects, such as broken tools or indexing plates from entering the pump suction. This distance is critical and must be maintained at all times.

To obtain the full flow rate it is recommended to choose for the pipework the nominal bore diameter of the pumps cross section for connection. Therefore pipe bends should be used, not pipe angles! The pipework must be qualified for occurring hydraulic pressure!



The pump should be operated continuously and NOT in on/off mode.

The pump must be mounted in such a way that rotating parts under the cover of the coolant tank can not be touched!

Unwanted objects, such as broken tools or indexing plates which still lie under the pump after stopping the working process must be taken out in regular intervals!

ATTENTION: any repair or maintenance work must be performed after the pump has been turned off and the shaft has come to a complete stop. Risk of injury!

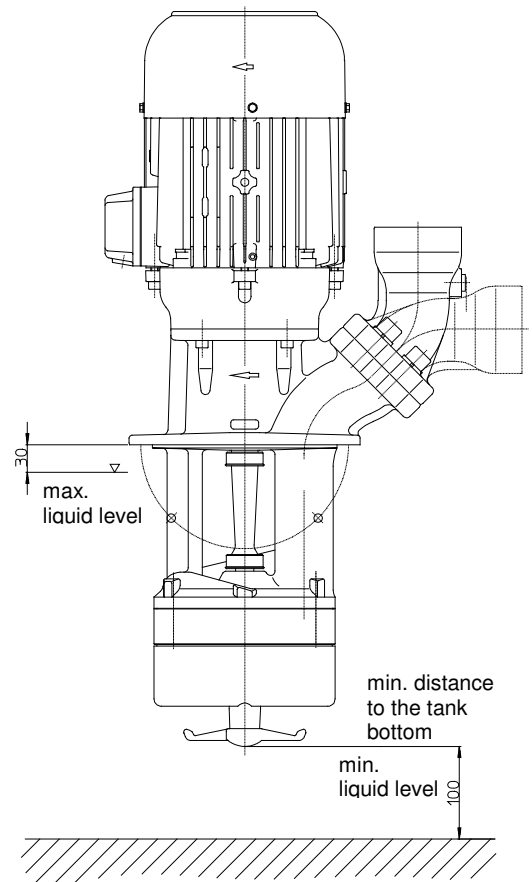

6 Start up / Shut down

Start up

Switch off at the mains.

After connection of the terminals close the terminal box.

Briefly start the motor and check the rotation according to the arrow on the top of the motor. **Looking through the fan cover of motor, the fan has to turn clockwise.**

If the direction is incorrect change over two of the power leads.

Shut down

Switch off at the mains.

Open terminal box and disconnect the power leads

Empty out the pump.



The temperature of the medium is not allowed to be higher than 175° F (80 °C).

The pumps are for continuous running against a closed sliding valve not suitable (plan bypass).

The pump should be operated in continual operation mode, not pulsed mode!
Pulsed mode causes increased wear due to the return flow of chips and additional load on the bearings.

ATTENTION

The pump should transport medium without chips for 1-2 minutes before being switched off!

7 Servicing and Maintenance

The surface of the motor must be kept free of dirt.

The motor shaft is spinning in permanently greased ball bearings (with special grease and increased bearing play) and does not require any special maintenance. Spare parts are readily available from stock.

8 Trouble shooter's guide

Fault	Cause	Remedy
Motor does not start, no motor noise	At least two of the power supply leads have failed	Check fuses, terminals and supply leads
Motor does not start, humming noise.	One of the supply leads has failed Impeller faulty Motor bearing faulty	See above Replace impeller Replace bearing
Pump does not pump	liquid level too low Pump mechanism faulty Pipe blocked	Fill up liquid replace pump mechanism Clean pipe
Insufficient flow and pressure	Wrong direction of rotation of impeller Pump mechanism silted up Worn pump mechanism	Change over two power supply leads Clean pump mechanism Replace pump mechanism
Power consumption is too high	Wrong direction of rotation of impeller Lime or other deposits mechanical friction	See above See above repair pump

Spare parts are available from the supplier.

Standard commercially available parts are to be purchased in accordance with the model type.

The ordering of spare parts should contain the following details:

- 1. Pumptype**
e.g. SFC1150S 390
- 2. Pump No.**
e.g. 06063085
The date of the construction year is a component of the pumps type number.
- 3. Voltage, Frequency and Power**
Take item 1, 2 and 3 from the nameplate
- 4. Spare part with item No.**
e.g. Intake cover item No. 53

Brinkmann Pumps, INC.
K. H. Brinkmann GmbH & Co. KG
47060 Cartier DRIVE
Wixom, MI 48393
Phone: 248-926-9400
Fax.: 248-926-9405
www.BrinkmannPumps.com
contact@BrinkmannPumps.com

Subject to change without prior notice.

Order - No.: BAS6085

9 Spare part list for the cutter pumps of the series SFC850...1150

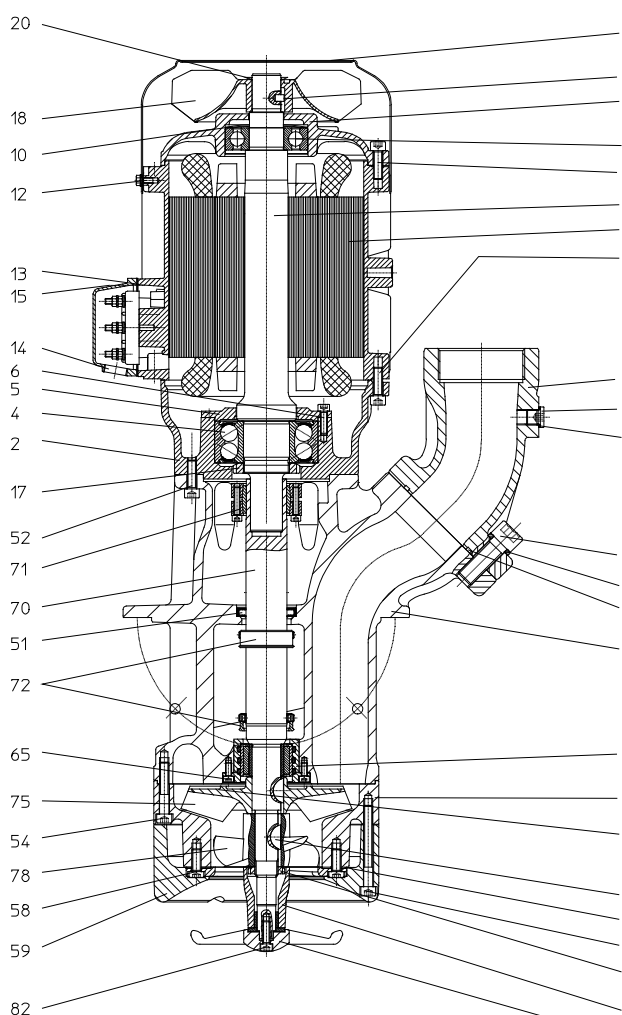

Item	Description	
1	Stator with terminal board	
2	Motor flange	
3	Socket head cap screw with lock	DIN 912
4	Ball bearing	DIN 628
5	Bearing cover	
6	Socket head cap screw	DIN 912
7	End shield	
8	Socket head cap screw with lock	DIN 912
9	Ball bearing	DIN 625
10	Bearing spring washer	
11	Fan cover	
12	Thread rolling screw	DIN 7500
13	Gasket	
14	Terminal box	
15	Socket head cap screw with lock	DIN 912
16	Shaft with rotor	
17	Shaft nut	
18	Fan	
19	Parallel pin	DIN 7
20	Retaining ring	
50	Pump body	
51	Shaft seal	
52	Socket head cap screw wit lock	DIN 912
53	Intake cover	
54	Socket head cap screw wit lock	DIN 912
55	Washer	
56	Chip breaker	
58	Socket head cap screw wit lock	DIN 7984
59	Inlet cover	
60	Socket head cap screw wit lock	DIN 912
61	Bushing cartridge assembly	
65	Socket head cap screw wit lock	DIN 912
70	Insert shaft	
71	Shaft clamp	
72	Splash ring	
75	Impeller	
76	Woodruff key	DIN 6888
78	Suction screw	
79	Woodruff key	DIN 6888
80	Shaft nut	
81	Agitator	
82	Socket head cap screw with lock	DIN 912
92	Joining socket	
93	Socket head cap screw	DIN 912
94	Spring washer	DIN 7980
95	O-ring	
96	Screw plug	DIN 908
97	Sealing ring	DIN 7603

Tightening torques for screwed connections

Thread - Ø	M5	M6	M8	M16
Strength classes	4.8	8.8	8.8	
Tightening torque in ft. lbs. (Nm)	2.2 (3)	3.3 (4.5)	15 (20)	45 (60) Pos. 93

10 Repair Instructions / Replacing shaft clamps and shafts

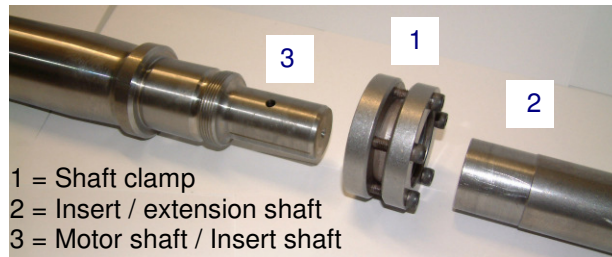

Dismantling the insert shaft or extension shaft

- Disconnect the submersible pump from the mains both electrically and mechanically.
- Set the pump down on the fan cover. Dismantle the pump unit and the extension pump body (if appropriate).
- Loosen the screws on the shaft clamp (1) one after the other.

Note: Do not, under any circumstances, remove the screws completely, **danger of injury!**

- Remove the extension shaft (2) and shaft clamp (1).
- Dismantle the pump body.
- Loosen the screws on the shaft clamp (1) (see above), pull the insert shaft (2) off the motor shaft (3).

Mounting the insert shaft and the extension shaft

- Set the motor down on the fan cover.
- Position the shaft clamp (1) (use a new shaft clamp) in the centre of the cranked clamping diameter (2) of the insert shaft.
- Insert the motor shaft (3) into the insert shaft (2).

Tighten:

- **Mark the first screw and tighten all the screws evenly by hand, one after the other in a clockwise direction (not cross-ways).**
- Use a torque screwdriver to tighten each screw first with 1.5 ft. lbs (2 Nm) then with 2.6 ft. lbs. (3.5 Nm) and finally with 3.7 ft. lbs. (5 Nm) (in a clockwise direction again).
- Mount the pump body.

Further assembly is carried out as before.

Note: Note torques for the screw connections!

When putting the pump back into use, **make sure the direction of rotation is correct!**

11.

WARRANTY

Brinkmann Pumps, Inc. warrants that the product contained herein conforms to the description in Brinkmann's catalog and that if this product shall fail to conform to the description thereof or to any express or implied warranty, Brinkmann shall, upon written notice of such nonconformity within one year of the date of its shipment from BRINKMANN'S plant, repair or replace such non-conforming material at the original point of delivery. Brinkmann will furnish instructions for disposition of the goods. If, however, Brinkmann provides a written warranty, as to this specific product, which is not in conformity to the above warranty, then as to such specific product, the specific written warranty shall prevail.

In addition to the warranty that this product will conform to the description in Brinkmann's catalog and that any such non-conforming material will be repaired or replaced, as above stated, BRINKMANN further warrants that it conveys good title to this product, free of all liens of any kind whatever unknown to the first Buyer. These are the sole warranties of BRINKMANN with respect to this product. BRINKMANN MAKES NO FURTHER WARRANTY OF ANY KIND, EXPRESS OR IMPLIED. ALL IMPLIED WARRANTIES OF MERCHANTABILITY AND FITNESS ARE HEREBY DISCLAIMED BY BRINKMANN AND EXCLUDED FROM THIS SALE.

The Buyer's exclusive and sole remedy on account or in respect of the product herein contained that does not conform to the description thereof, or to any express or implied warranty, shall be to secure replacement thereof as aforesaid. BRINKMANN shall not in any event be liable for the cost of any labor expended on any such material or for any special, direct, indirect, incidental or consequential damages to anyone by reason of the fact that such goods do not conform to the description thereof or to any express or implied warranty.