

Hydraulic Features

BRINKMANN's program of coolant pumps offers appropriate design approaches for different applications.

Based upon the centrifugal pump system, we offer immersion pumps with open and semi-open impellers for unfiltered coolants as series TB, TA/STA and TS are. Free flow-immersion pumps series SFT are suitable for heavy chip loads with coarse shreds.

Patented quick suctioning pumps series TL, TAL/SAL, SFL, SGL are provided for extreme suctioning of air inflated coolants.

Suction immersion pumps Series TAS/STS make it possible to connect to vacuum filters because of their single connection on the suction side (for instance, with a slot screen).

Immersion pumps series TC, TH for medium pressure get optimal hydraulic efficiency due to their closed impellers; simple pre-filtration is recommended.

High pressure in coolant systems is provided by screw pumps using longwearing silicon carbide capsules. Please ask for further applications by informing us about working conditions in your devices.

Please note that with all immersion pumps, the highest fill level of coolant should stay a few inches below the fastening flange.

The pump characteristics, shown in this catalog, apply to water at 68 °F (20 °C) at 4.6 SSU (1 mm²/s). Higher viscosities need larger motors. Coolants of specific weight less than 1 need less power and more than 1 need more power.

Centrifugal pump pressure is stated as delivery head in Feet, (m) and PSI.

The diagrams of immersion pump types STA404; with semi-open impellers, and TC63S560, with closed impellers, show the rates for coolants of different viscosities and different specific weights in ft (m) and PSI (bar) respectively.

The viscogram shows examples of common oils. Upon request, oil curves for specific pumps can be provided.

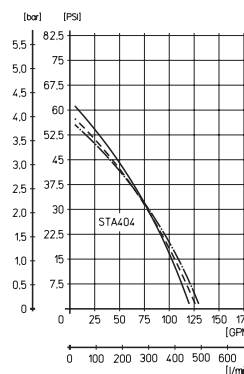
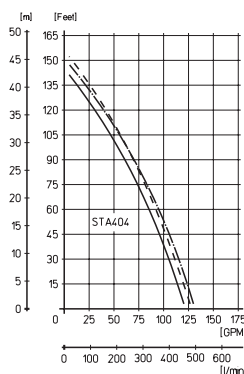

STA404
with semi-open
impellers

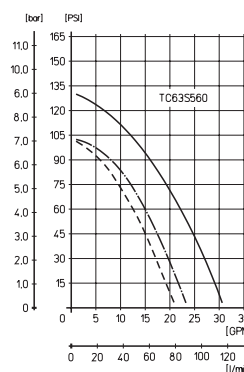
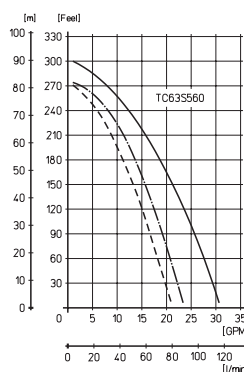

TC63
with closed impellers

Water ————
Oil - - - - - 210 SSU spec. weight
Oil - · - · - 415 SSU 0.87

Water ————
Oil - - - - - 210 SSU spec. weight
Oil - · - · - 415 SSU 0.87

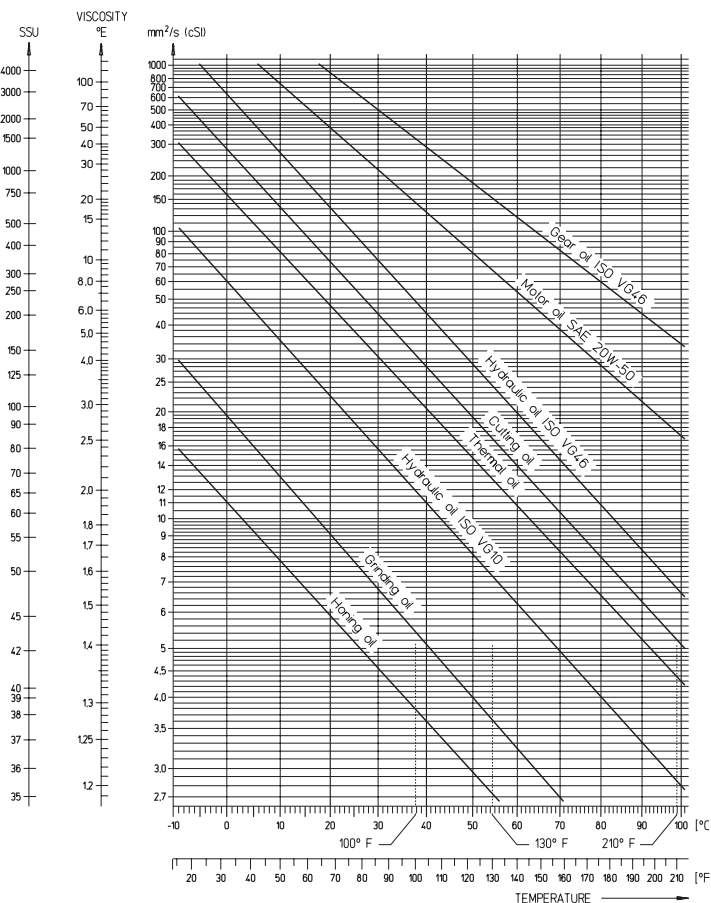

Technical Information

Lifting pump versions ST...

The comprehensive hydraulic modular design system ensures best possible adaptation to your specific application requirements.

Depending on whether water soluble coolant or oil is used as coolant during the machining process and depending on the application parameters several hydraulic options are available, including an integrated variable frequency drive, if selected.

The range includes standard lifting pumps such as the STA900 with 0.4 inch (10 mm) sphere size passage as well as the classic Vortex pumps such as the SFT1100 with a 2.0 inch (50 mm) sphere size passage all the way to the cutter pump with its integrated cutting mechanism. All pumps are equipped with a 45 degree flange which allows for a either vertical or horizontal pipe connection and which offers a NPT 1/4 (G 1/4) port for the connection of a pressure gauge.

Lifting pump versions ST...

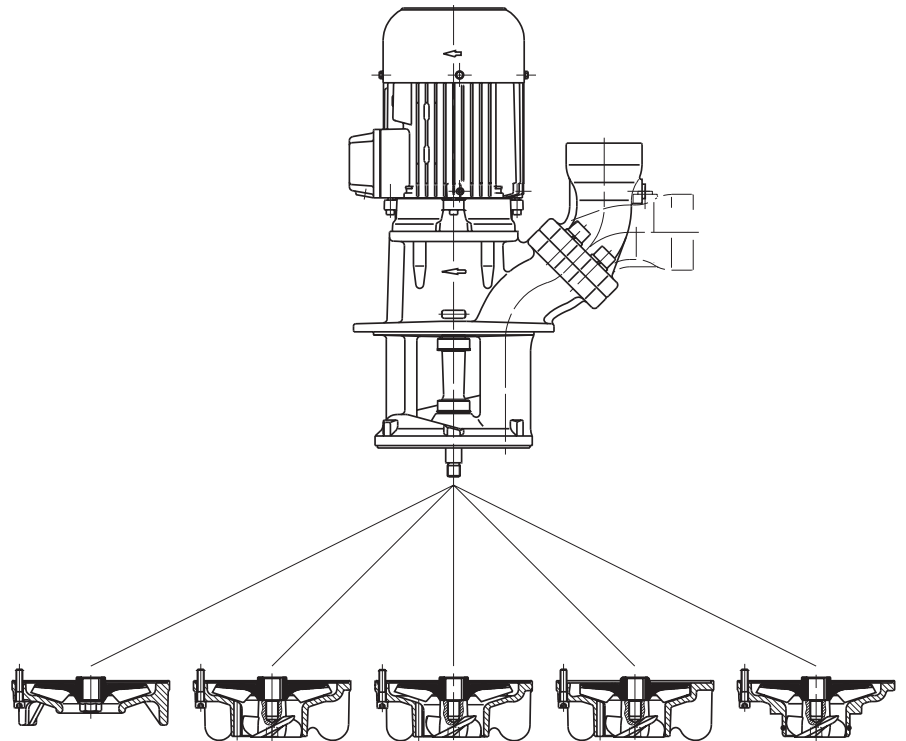

STA	SAL	SFL	SGL	STS
Immersion pumps	Quick suctioning immersion pumps	Quick suctioning immersion pumps	Quick suctioning immersion pumps	Suction immersion pump
Lifting pump for standard applications	Lifting pump for emulsions with some percentage of air	Lifting pump for emulsions/oil with increased percentage of chips	Lifting pump for oil with high percentage of air (fine machining)	Pump for vacuum filter, e.g. on split sieve basis for vacuums from -5 ... -7 PSI (-0.3 ... -0.5 bar)
	Quick suctioning feature	Quick suctioning feature	Quick suctioning feature	

SFL Lifting pump versions

	Impeller material	Inlet cover material	Slurping mode	Chip handling capabilities	Max. chip to coolant ratio by weight	Type	Chip diameter		Chip length		
							Inch / mm	Inch / mm			
SFL...Standard	cast steel	cast steel	yes	colored metal, aluminium, cast iron	1%	SFL 650	0.3 / 8	0.6 / 15	SFL 850	0.4 / 10	0.8 / 20
						SFL1150	0.6 / 15	1.18 / 30	SFL1350	0.6 / 15	1.18 / 30
						SFL1550	0.6 / 15	1.18 / 30	SFL1850	0.6 / 15	1.18 / 30
SFL...CM1	CrMo	cast steel	yes	steel, medium alloyed steel	1%	SFL2350	1.0 / 25	1.97 / 50			
SFL...CM3	CrMo	CrMo	yes	forged materials, high alloyed steels, hardened steels	1%						

All information stated above is only intended as a general guide line for your system layout. Prior to placing your order please consult with our highly skilled sales force regarding your specific application in order to ensure proper pump selection.

Lifting pump versions SFC

Cutter Pumps SFC

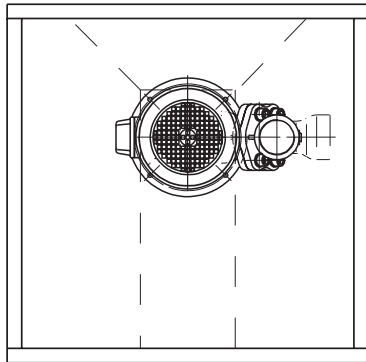
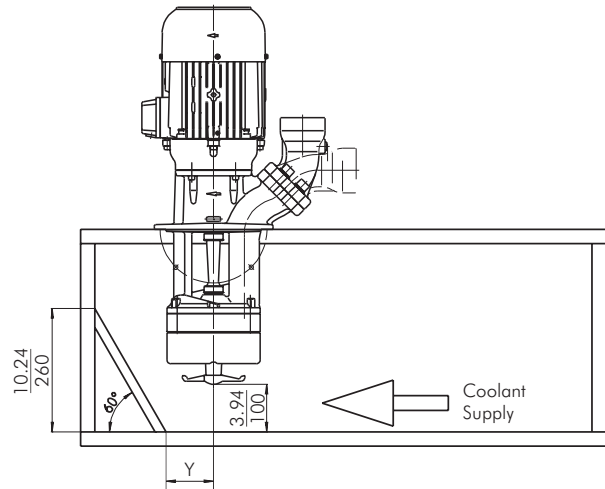
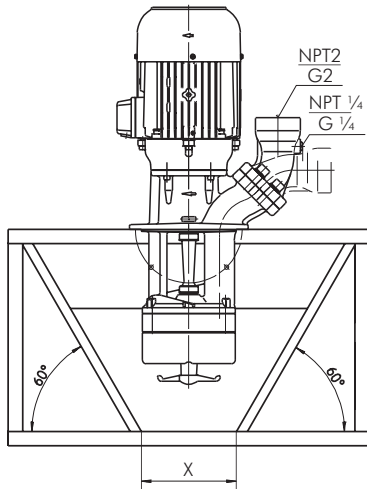

	X Inch / mm	Y Inch / mm
SFC 850	7.87 / 200	3.94 / 100
SFC1150	7.87 / 200	3.94 / 100
SFC1550	10.83 / 275	5.5 / 140
SFC1850	10.83 / 275	5.5 / 140
SFC2350	10.83 / 275	5.5 / 140

Dimensions in Inches / mm

The cutter pumps of the series SFC are suited for cutting aluminium chips or similar materials and for pumping these materials along with the coolant fluid. An agitator located at the pump suction helps to break up and separate any large bundles of chips or birds nests which reach the pump suction. The hardened cutting unit (>60 HRC) is cutting chips and the semi-open impeller with its large clearances allows to pump the particles along with the coolant fluid from the machine back to the filter. The SFC pumps are capable of handling chip to coolant ratios of up to 1.5% by weight.

The cutter pump is equipped with a maintenance free shock absorbing bushing which has outstanding dry running capabilities. Instead of cycling the pumps, the SFC pumps should be run continuously in order to prevent chips from entering the back plane of the impeller.

The agitator must be located 4 inches (100 mm) above the tank bottom in order to prevent unwanted objects, such as broken tools or indexing plates, from entering the pump suction.

The walls of the tank around the pump should be sloped at a 60 degree angle to avoid chips from collecting at the tank bottom. The coolant supply should be aimed directly at the pump to ensure that all contamination, including chip bundles, reach the pump suction (please refer to the above tank design as a guide line for your tank layout).

Pumps of the SFC series have the following unique characteristics:

- Oversized motor to transfer additional cutting forces via the driving shaft if necessary
- Axial impeller which has been optimized for the cutting process
- Adjustable gap between both cutting blades for preventive maintenance (due to stiff motor bearing and shaft design)
- Dry running capability
- Maintenance free and shock absorbing bearing bushing

All information stated above is only intended as a general guide line for your system layout. Prior to placing your order please consult with our highly skilled sales force regarding your specific application in order to ensure proper pump selection.

45 degree flanges

Brinkmann Pumps with 45 degree flanges

Most Brinkmann pumps with motors larger than 1.6 HP (1.2 kW) are equipped with the user friendly 45 degree flange connection which allows for either vertical or horizontal pipe connection.

Each flange is equipped with an additional NPT 1/4 (G 1/4) pressure gauge connection.

For optimized chip transport and to avoid chip blockages inside the pumps, all flow is directed in long soft turns. All flanges are designed in a way that any cross section changes down stream are always increasing never decreasing in order to prevent bottle necks inside the pump.

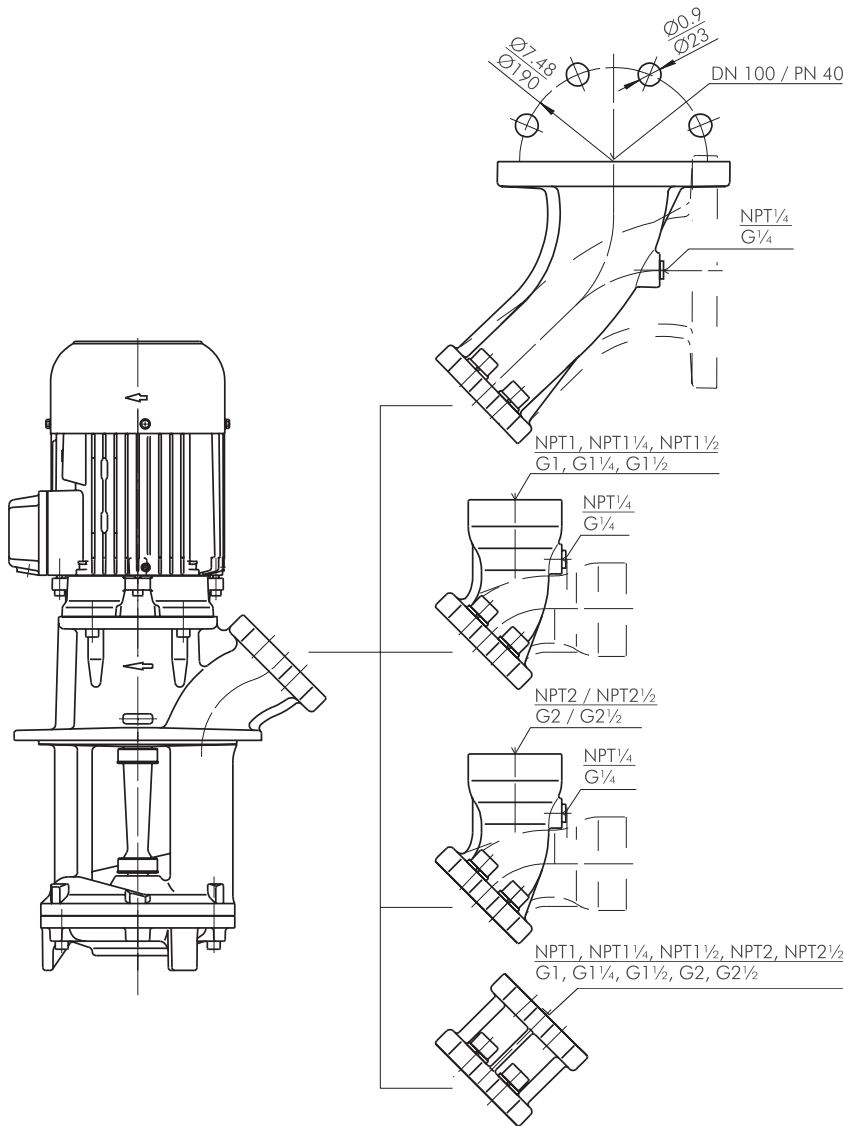

Dimensions in Inches / mm

Discharge port with G available upon request.

1. DN 100 Flanges

Available upon request for all pumps equipped with the NPT 2 1/2, NPT 2 (G 2 1/2, G 2) flange.

2. SAE Flange NPT 1, NPT 1 1/4, NPT 1 1/2 (G 1, G 1 1/4, G 1 1/2)

Standard as shown on data sheets. Upon request also available for TC and TH pumps. NPT 1 1/2 (G 1 1/2) can be specified instead of NPT 1 1/4 (G 1 1/4) and vice versa without surcharge.

3. Flange NPT 2 1/2, NPT 2 (G 2 1/2, G 2)

Standard as shown on data sheets. NPT 2 (G 2) is available upon request instead of NPT 2 1/2 (G 2 1/2) without surcharge.

4. Extension flange NPT 1 1/2 (G 1 1/2) and NPT 2 1/2 (G 2 1/2)

Extension flanges NPT 1 1/2 (G 1 1/2) and NPT 2 1/2 (G 2 1/2): Standard for pumps with motor sizes larger than 20 HP (15 kW). Available upon request for all other pumps with SAE flange.